

### Ana Şanzıman Modeli

MERCEDES G 3 36

MERCEDES G 3 45

MERCEDES G 3 55

MERCEDES G 3 60

ZF 16 S 130

ZF 16 S 150

ZF 16 S 160

ZF 16 S 190

ZF 16 S 220

ZF 16.190

ZF 20 S 190

ZF 20.190

ZF 4 90

ZF 4 S 120

ZF 4 S 150 GP

ZF 5 110 GP

ZF 5 111 GP

ZF 5 150

ZF 5 24

ZF 5 35

ZF 5 45

ZF 5 50

ZF 5 50

ZF 5 65

ZF 5 90 GP

ZF 5 92 GP

ZF 5 S 110 GP

ZF 5 S 111 GP

ZF 6 36

ZF 6 65

ZF 6 70

ZF 6 75

ZF 6 80

ZF 6 90

ZF 6 S 800 OD

ZF 6 S 800 TO

ZF 65

ZF AK 6 90

ZF S 110

ZF S 4 120

ZF S 5 24

ZF S 5 35

ZF S 5 90

ZF S 6 65

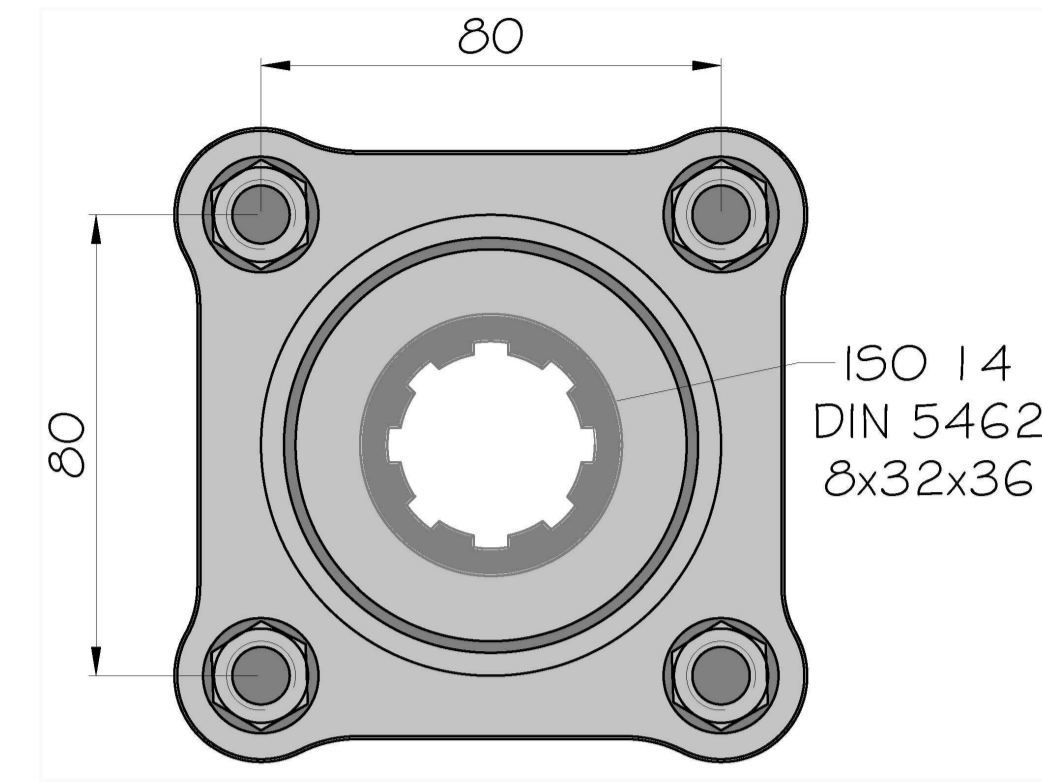

Elektrikli Yağ Müşürü

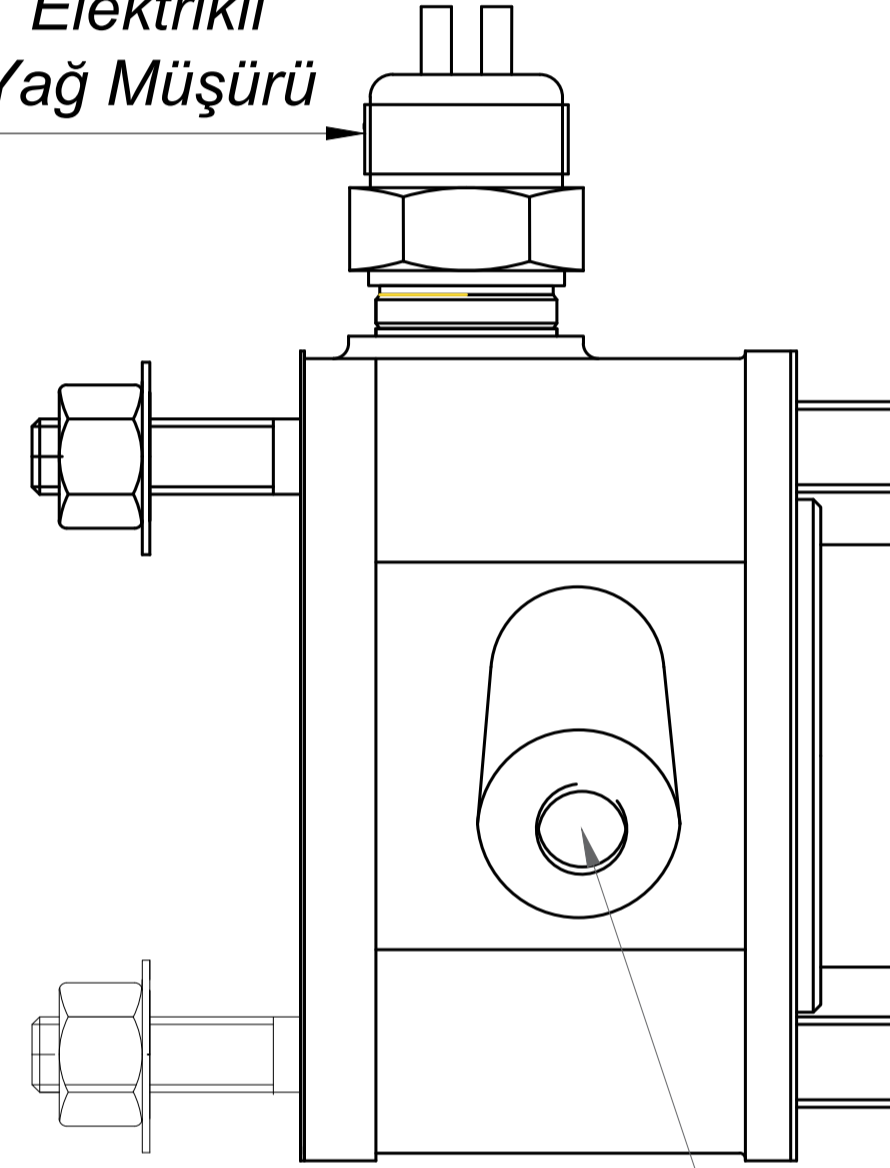

Hava Hortum Girişi R 1/4

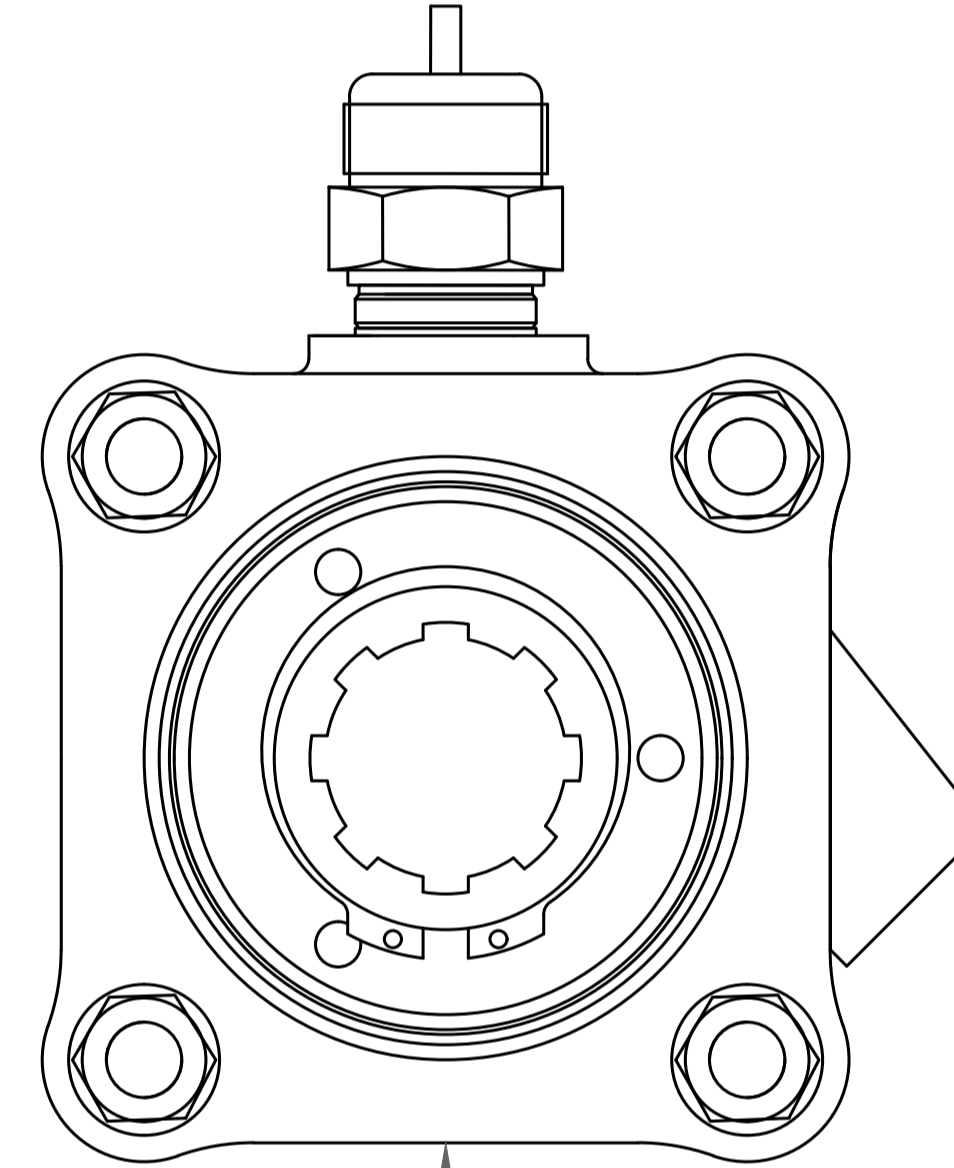

Pompa Bağlantısı Kare Flanş Tip PTO



PTO Bağlantı Yeri Aracın Arka Tarafı (Kuyruktan)

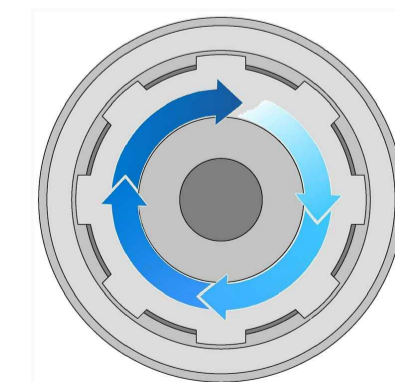

PTO Mil Dönüş Yönü Sağa (Saat Yönü)

Pto Kodu	136AC2M
Dişli Tipi	Düz
Pto Tipi	Tek Dişli / Müşürlü
Tork Nm	300
Güç Kw	22
Tahvil Oranı	1,1
Bağlantı Yeri	Kuyruktan
Kontrol Sistemi	Hava Yastıklı
Pto Mil Dönüş Yönü	Sağa
Ağırlık Kg.	5,00



Ürün Kodu	1 3 6 A C 2 M
	Müşürlü
	Kare Flanşlı - ISO 14 / DIN 5462 - 8x32x36
	Akuple
	Havalı